

CK



1~

3~

CKm 50

CK 50

CKm 50-BP

CK 50-BP

CKm 80

CK 80

CKm 90

CK 90

CKm 50/INT

—

CKm 50-BP/INT

—

CKm 80/INT

—

CKm 90/INT

—

CKm 50-BP/NZ

—

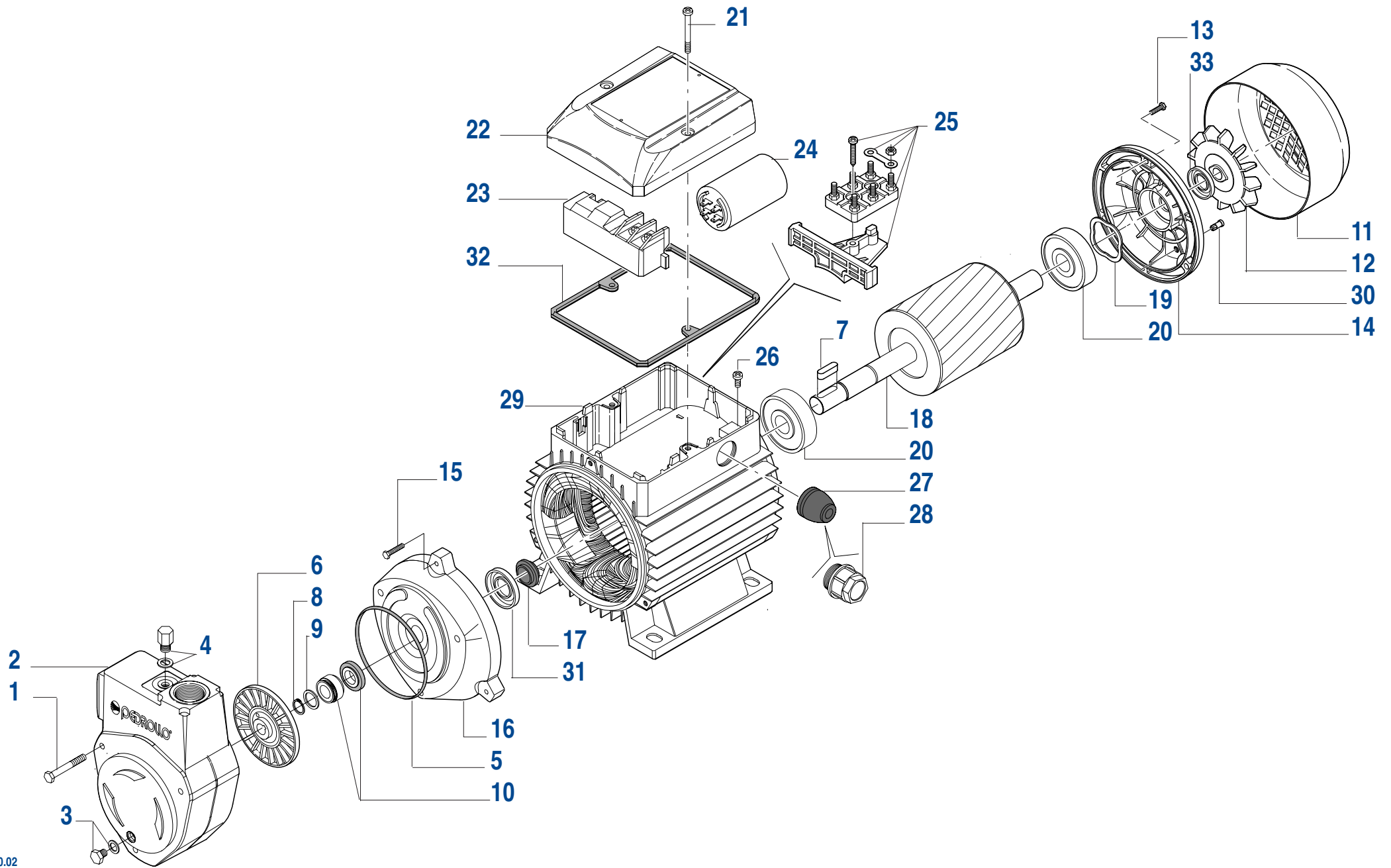

02.40.02

N°	Codice Code Reference Codigo	CK 50	Descrizione	Description	Description	Descripción
1	1160451	x	Vite corpo pompa	Pump body screw	Vis du corps de pompe	Tornillo del cuerpo bomba
2	851CRCK51	x	Corpo pompa	Pump body	Corps de pompe	Cuerpo bomba
3	119003C	x	Tappo con rondella	Plug with washer	Bouchon avec rondelle	Tapón con arandela
4	119000C1	x	Tappo con rondella	Plug with washer	Bouchon avec rondelle	Tapón con arandela
5	11514202362	x	Guarnizione OR per corpo pompa	Pump body O-Ring	Joint torique du corps de pompe	Junta tórica del cuerpo bomba
6	860GRCK50	x	Girante	Impeller	Roue	Rodete
7	114800	x	Linguetta inox per girante	Stainless steel impeller key	Clavette de la roue en acier inox	Chaveta del rodete en acero inoxidable
8	114600	x	Anello di sicurezza Ø 12 mm	Circlip Ø 12 mm	Circlips Ø 12 mm	Anillo de seguridad Ø 12 mm
9	114700P	x	Rondella	Washer	Rondelle	Arandela
10	11516101203	x	Tenuta meccanica Ø 12 mm VITON	Mechanical seal Ø 12 mm VITON	Garniture mécanique Ø 12 mm VITON	Sello mecánico Ø 12 mm VITON
11	14CL06	x	Copriventola	Fan cover	Capot de ventilateur	Tapa del ventilador
12	14VN06	x	Ventola	Fan	Ventilateur	Ventilador
13	116001T	x	Vite	Screw	Vis	Tornillo
14	SC0600	x	Scudo	End shield	Flasque arrière	Tapa motor
15	116001T	x	Vite	Screw	Vis	Tornillo
16	SC070LN	x	Lanterna di raccordo	Motor bracket	Lanterne de raccordement	Soporte motor
17	115104	x	Deflettore	Deflector	Deflecteur	Deflector
18	RTP061B04A	x	Albero con rotore	Shaft with rotor	Arbre avec rotor	Eje con rotor
19	114000	x	Molla di compensazione	Compensation spring	Ressort de compensation	Muelle de compensación
20	113001	x	Cuscinetto a sfere	Ball bearing	Roulement à billes	Rodamiento
21	116038	x	Vite	Screw	Vis	Tornillo
22	14COK06IPA	x	Coprimorsettiera	Terminal box	Couvercle de boîtier à bornes	Tapa bornes
25	ASSMORS01	x	Morsettiera	Terminal board	Boîte à bornes	Placa bornes
26	116031T	x	Vite	Screw	Vis	Tornillo
27	117060	x	Passacavo	Cable grommet	Passe câble	Pasacable
28	117109	x	Pressacavo	Cable gland	Presse étoupe	Prencacable
29	CA061BP0A	x	Cassa motore con statore avvolto (V 230/400)	Motor casing with windings (V 230/400)	Carcasse moteur avec bobinage (V 230/400)	Caja motor con estator bobinado (V 230/400)

VERSIONE MONOFASE - SINGLE PHASE VERSION - VERSION MONOPHASE - VERSION MONOFASICA

18	RTP061C15B	x	Albero con rotore	Shaft with rotor	Arbre avec rotor	Eje con rotor
23	114421	x	Morsettiera	Terminal board	Boîte à bornes	Placa bornes
24	111012F	x	Condensatore 12,5 µF	Capacitor 12,5 µF	Condensateur 12,5 µF	Condensador 12,5 µF
29	CA061CP0A1	x	Cassa motore con statore avvolto (V 230)	Motor casing with windings (V 230)	Carcasse moteur avec bobinage (V 230)	Caja motor con estator bobinado (V 230)

PROTEZIONE IP55 - IP55 PROTECTION - PROTECTION IP55 - PROTECCION IP55

14	SC06001	x	Scudo	End shield	Flasque arrière	Tapa motor
21	116035	x	Guarnizione	Screw	Vis	Tornillo
30	119012	x	Tappo	Plug	Bouchon	Tapón
31	11514501215	x	Anello di tenuta	Sealing ring	Joint a lèvres	Anillo de cierre
32	1170501	x	Guarnizione	Gasket	Joint	Junta
33	1151045	x	Anello di tenuta	Sealing ring	Joint a lèvres	Anillo de cierre

Con riserva di modifiche.
 Technical modifications reserved.
 Sous réserve de modification technique.
 Reservado el derecho a introducir modificaciones.

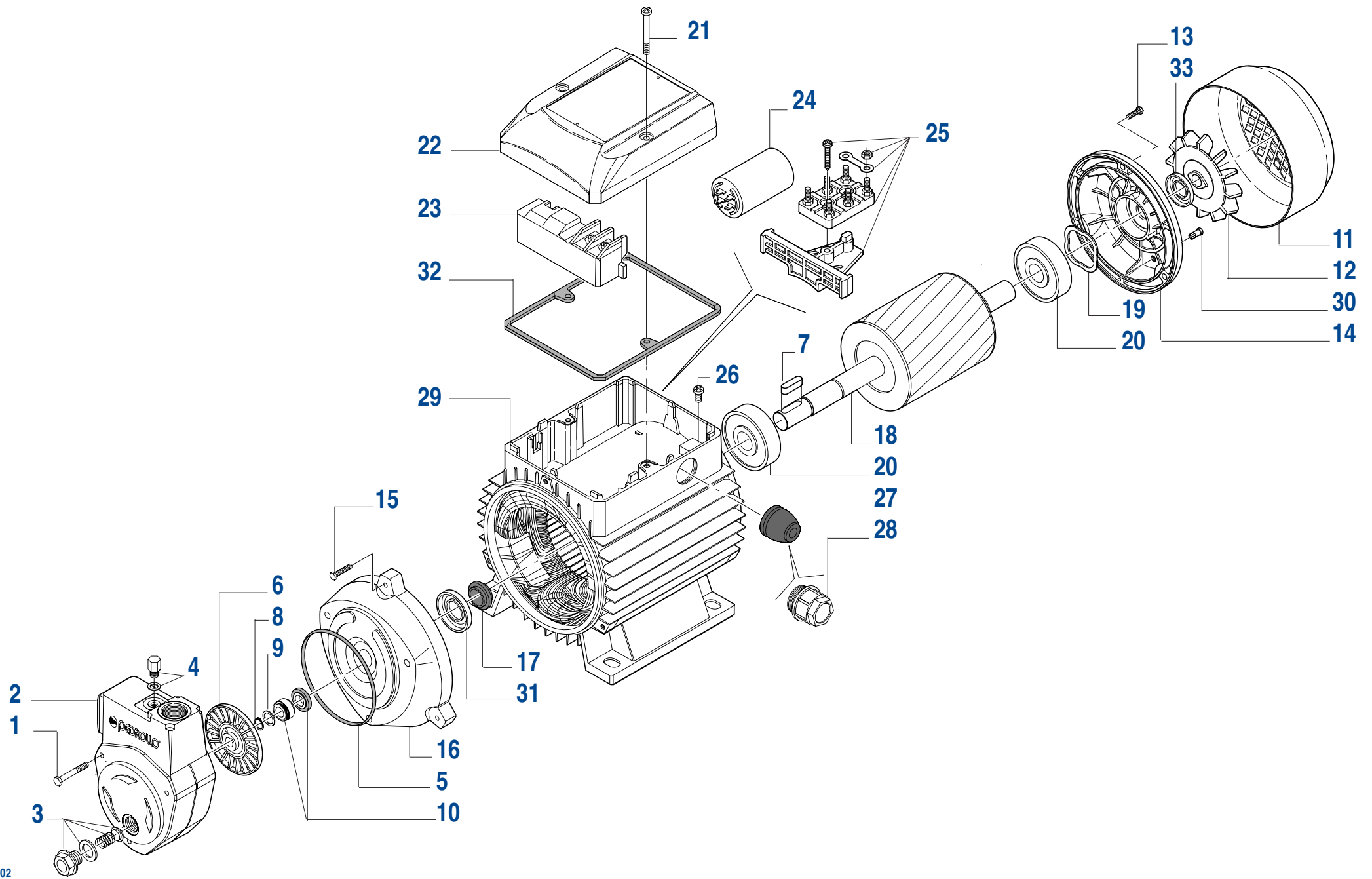

02.40.02

N°	Codice Code Reference Codigo	CK 50-BP	Descrizione	Description	Description	Descripción
1	1160451	x	Vite corpo pompa	Pump body screw	Vis du corps de pompe	Tornillo del cuerpo bomba
2	851CRCK50	x	Corpo pompa	Pump body	Corps de pompe	Cuerpo bomba
3	119009	x	Tappo con valvola	Plug with valve	Bouchon avec clapet	Tapón con válvula
4	119000C1	x	Tappo con rondella	Plug with washer	Bouchon avec rondelle	Tapón con arandela
5	11514202362	x	Guarnizione OR per corpo pompa	Pump body O-Ring	Joint torique du corps de pompe	Junta tórica del cuerpo bomba
6	860GRCK50	x	Girante	Impeller	Roue	Rodete
7	114800	x	Linguetta inox per girante	Stainless steel impeller key	Clavette de la roue en acier inox	Chaveta del rodete en acero inoxidable
8	114600	x	Anello di sicurezza Ø 12 mm	Circlip Ø 12 mm	Circlips Ø 12 mm	Anillo de seguridad Ø 12 mm
9	114700P	x	Rondella	Washer	Rondelle	Arandela
10	11516101203	x	Tenuta meccanica Ø 12 mm VITON	Mechanical seal Ø 12 mm VITON	Garniture mécanique Ø 12 mm VITON	Sello mecánico Ø 12 mm VITON
11	14CL06	x	Copriventola	Fan cover	Capot de ventilateur	Tapa del ventilador
12	14VN06	x	Ventola	Fan	Ventilateur	Ventilador
13	116001T	x	Vite	Screw	Vis	Tornillo
14	SC0600	x	Scudo	End shield	Flasque arrière	Tapa motor
15	116001T	x	Vite	Screw	Vis	Tornillo
16	SC070LN	x	Lanterna di raccordo	Motor bracket	Lanterne de raccordement	Soporte motor
17	115104	x	Deflettore	Deflector	Deflecteur	Deflector
18	RTP061B04A	x	Albero con rotore	Shaft with rotor	Arbre avec rotor	Eje con rotor
19	114000	x	Molla di compensazione	Compensation spring	Ressort de compensation	Muelle de compensación
20	113001	x	Cuscinetto a sfere	Ball bearing	Roulement à billes	Rodamiento
21	116038	x	Vite	Screw	Vis	Tornillo
22	14COK06IPA	x	Coprimorsettiera	Terminal box	Couvercle de boîtier à bornes	Tapa bornes
25	ASSMORS01	x	Morsettiera	Terminal board	Boîte à bornes	Placa bornes
26	116031T	x	Vite	Screw	Vis	Tornillo
27	117060	x	Passacavo	Cable grommet	Passe câble	Pasacable
28	117109	x	Pressacavo	Cable gland	Presse étoupe	Prensacable
29	CA061BP0A	x	Cassa motore con statore avvolto (V 230/400)	Motor casing with windings (V 230/400)	Carcasse moteur avec bobinage (V 230/400)	Caja motor con estator bobinado (V 230/400)

VERSIONE MONOFASE - SINGLE PHASE VERSION - VERSION MONOPHASE - VERSION MONOFASICA

18	RTP061C15B	x	Albero con rotore	Shaft with rotor	Arbre avec rotor	Eje con rotor
23	114421	x	Morsettiera	Terminal board	Boîte à bornes	Placa bornes
24	111012F	x	Condensatore 12,5 µF	Capacitor 12,5 µF	Condensateur 12,5 µF	Condensador 12,5 µF
29	CA061CP0A1	x	Cassa motore con statore avvolto (V 230)	Motor casing with windings (V 230)	Carcasse moteur avec bobinage (V 230)	Caja motor con estator bobinado (V 230)

PROTEZIONE IP55 - IP55 PROTECTION - PROTECTION IP55 - PROTECCION IP55

14	SC06001	x	Scudo	End shield	Flasque arrière	Tapa motor
21	116035	x	Guarnizione	Screw	Vis	Tornillo
30	119012	x	Tappo	Plug	Bouchon	Tapón
31	11514501215	x	Anello di tenuta	Sealing ring	Joint a lèvres	Anillo de cierre
32	1170501	x	Guarnizione	Gasket	Joint	Junta
33	1151045	x	Anello di tenuta	Sealing ring	Joint a lèvres	Anillo de cierre

Con riserva di modifiche.
 Technical modifications reserved.
 Sous réserve de modification technique.
 Reservado el derecho a introducir modificaciones.

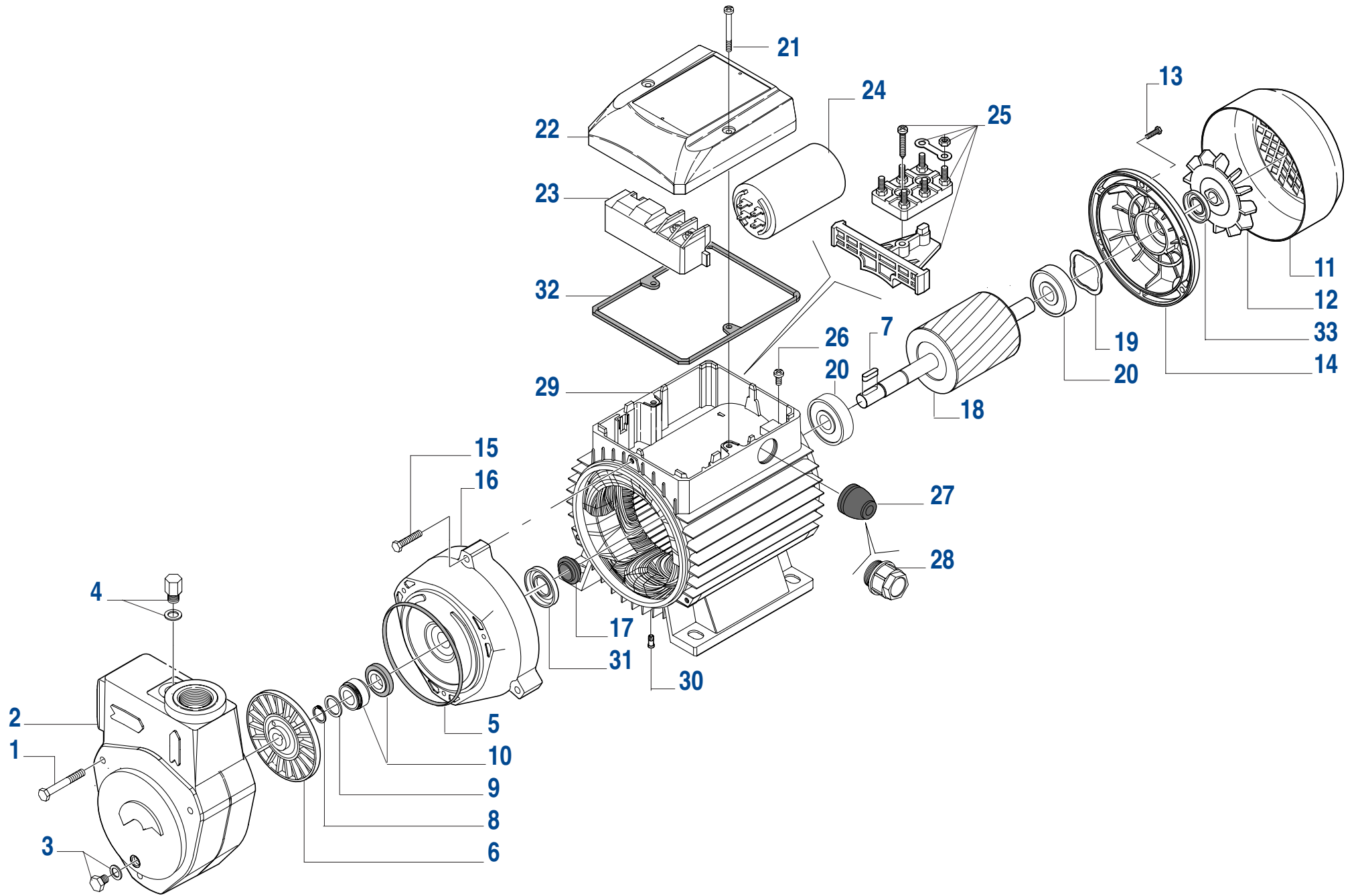

02.40.02

VERSIONE TRIFASE - THREE PHASE VERSION - VERSION TRIPHASE - VERSION TRIFASICA

50 Hz

N°	Codice Code Reference Codigo	CK 80	CK 90	Descrizione	Description	Description	Descripción
1	1160081	x	x	Vite corpo pompa	Pump body screw	Vis du corps de pompe	Tornillo del cuerpo bomba
2	851CRCK80	x	x	Corpo pompa	Pump body	Corps de pompe	Cuerpo bomba
3	119003C	x	x	Tappo con rondella	Plug with washer	Bouchon avec rondelle	Tapón con arandela
4	119000C1	x	x	Tappo con rondella	Plug with washer	Bouchon avec rondelle	Tapón con arandela
5	11514202364	x	x	Guarnizione OR per corpo pompa	Pump body O-Ring	Joint torique du corps de pompe	Junta tórica del cuerpo bomba
6	860GRCK80	x	x	Girante	Impeller	Roue	Rodete
7	114800	x	x	Linguetta inox per girante	Stainless steel impeller key	Clavette de la roue en acier inox	Chaveta del rodete en acero inoxidable
8	114600	x	x	Anello di sicurezza Ø 12 mm	Circlip Ø 12 mm	Circlips Ø 12 mm	Anillo de seguridad Ø 12 mm
9	114700P	x	x	Rondella	Washer	Rondelle	Arandela
10	11516101203	x	x	Tenuta meccanica Ø 12 mm VITON	Mechanical seal Ø 12 mm VITON	Garniture mécanique Ø 12 mm VITON	Sello mecánico Ø 12 mm VITON
11	14CL07	x	x	Copriventola	Fan hood	Capot de ventilateur	Tapa del ventilador
12	14VN07	x	x	Ventola	Fan	Ventilateur	Ventilador
13	116001	x	x	Vite	Screw	Vis	Tornillo
14	SC0700	x	x	Scudo	End shield	Flasque arrière	Tapa motor
15	116020	x	x	Vite	Screw	Vis	Tornillo
16	SC075LN	x	x	Lanterna di raccordo	Motor bracket	Lanterne de raccordement	Soporte motor
17	115105	x	x	Deflettore	Deflector	Deflecteur	Deflector
18	RTP071BC12	x	x	Albero con rotore	Shaft with rotor	Arbre avec rotor	Eje con rotor
19	114001	x	x	Molla di compensazione	Compensation spring	Ressort de compensation	Muelle de compensación
20	113002	x	x	Cuscinetto a sfere	Ball bearing	Roulement à billes	Rodamiento
21	116036	x	x	Vite	Screw	Vis	Tornillo
22	14COK06IPQ	x	x	Coprimorsettiera	Terminal box	Couvercle de boîtier à bornes	Tapa bornes
25	ASSMORS01	x	x	Morsettiera	Terminal board	Boîte à bornes	Placa bornes
26	116031	x	x	Vite	Screw	Vis	Tornillo
27	117071	x	x	Passacavo	Cable grommet	Passe câble	Pasacable
28	117110	x	x	Pressacavo	Cable gland	Presse étoupe	Prensacable
29	CA071BCP0A	x	x	Cassa motore con statore avvolto (V 230/400)	Motor casing with windings (V 230/400)	Carcasse moteur avec bobinage (V 230/400)	Caja motor con estator bobinado (V 230/400)

VERSIONE MONOFASE - SINGLE PHASE VERSION - VERSION MONOPHASE - VERSION MONOFASICA

18	RFP071C12	x	x	Albero con rotore	Shaft with rotor	Arbre avec rotor	Eje con rotor
23	114431	x	x	Morsettiera	Terminal board	Boîte à bornes	Placa bornes
24	111016F	x		Condensatore 16 µF	Capacitor 16 µF	Condensateur 16 µF	Condensador 16 µF
24	111020F	x		Condensatore 20 µF	Capacitor 20 µF	Condensateur 20 µF	Condensador 20 µF
29	CA071CP0A1	x	x	Cassa motore con statore avvolto (V 230)	Motor casing with windings (V 230)	Carcasse moteur avec bobinage (V 230)	Caja motor con estator bobinado (V 230)

PROTEZIONE IP55 - IP55 PROTECTION - PROTECTION IP55 - PROTECCION IP55

14	SC07001	x	x	Scudo	End shield	Flasque arrière	Tapa motor
21	116039	x	x	Vite	Screw	Vis	Tornillo
30	119012	x	x	Tappo	Plug	Bouchon	Tapón
31	11514501223	x	x	Anello di tenuta	Sealing ring	Joint à lèvres	Anillo de cierre
32	1170501	x	x	Guarnizione	Gasket	Joint	Junta
33	1151046	x	x	Anello di tenuta	Sealing ring	Joint à lèvres	Anillo de cierre

Con riserva di modifiche.
 Technical modifications reserved.
 Sous réserve de modification technique.
 Reservado el derecho a introducir modificaciones.

02.40.02

CK 80 (A) - CK 90 (A)

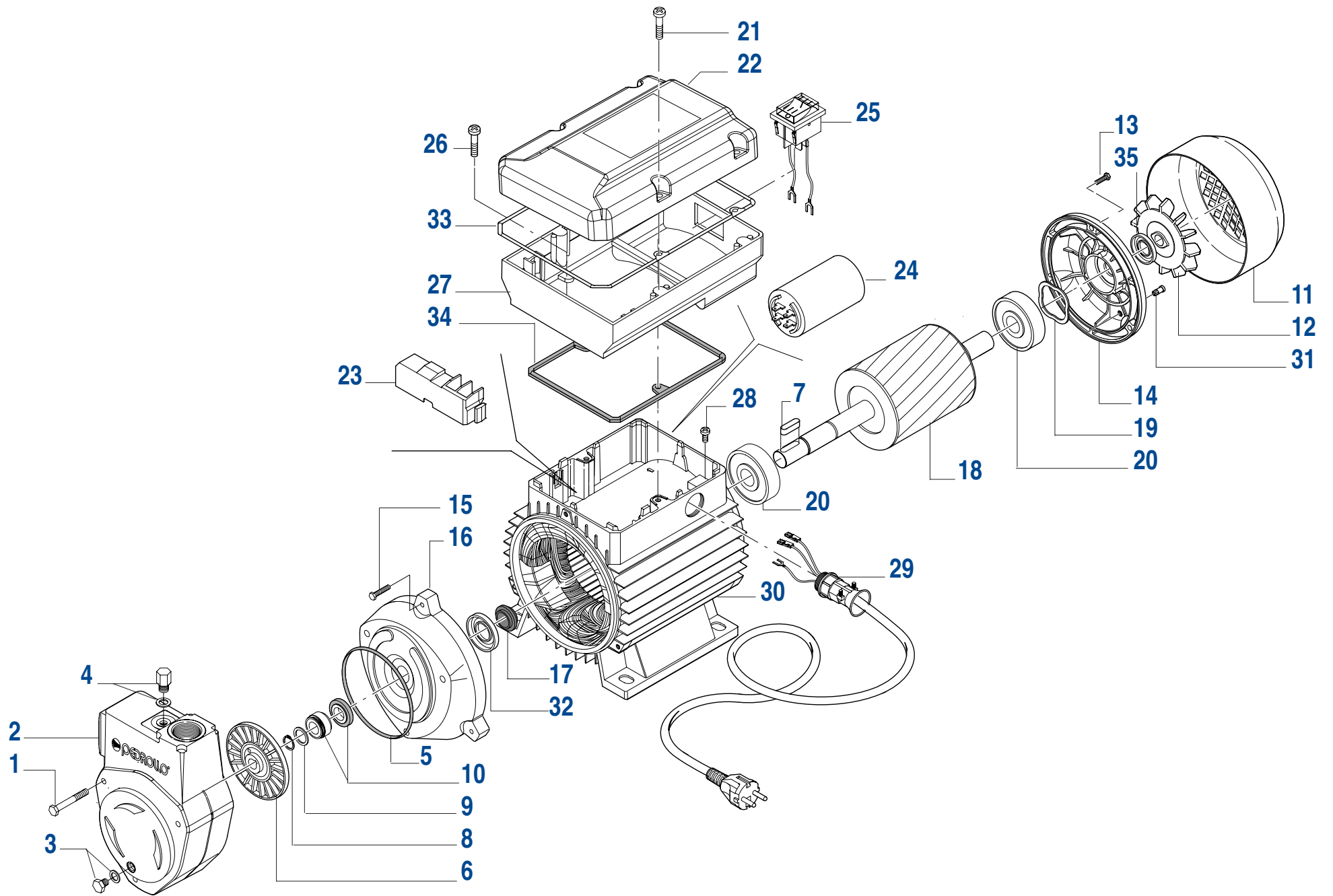

02.40.02

N°	Codice Code Reference Codigo	CKm 50/INT	Descrizione	Description	Description	Descripción
1	1160451	x	Vite corpo pompa	Pump body screw	Vis du corps de pompe	Tornillo del cuerpo bomba
2	851CRCK51	x	Corpo pompa	Pump body	Corps de pompe	Cuerpo bomba
3	119003C	x	Tappo con rondella	Plug with washer	Bouchon avec rondelle	Tapón con arandela
4	119000C1	x	Tappo con rondella	Plug with washer	Bouchon avec rondelle	Tapón con arandela
5	11514202362	x	Guarnizione OR per corpo pompa	Pump body O-Ring	Joint torique du corps de pompe	Junta tórica del cuerpo bomba
6	860GRCK50	x	Girante	Impeller	Roue	Rodete
7	114800	x	Linguetta inox per girante	Stainless steel impeller key	Clavette de la roue en acier inox	Chaveta del rodete en acero inoxidable
8	114600	x	Anello di sicurezza Ø 12 mm	Circlip Ø 12 mm	Circlips Ø 12 mm	Anillo de seguridad Ø 12 mm
9	114700P	x	Rondella	Washer	Rondelle	Arandela
10	11516101203	x	Tenuta meccanica Ø 12 mm VITON	Mechanical seal Ø 12 mm VITON	Garniture mécanique Ø 12 mm VITON	Sello mecánico Ø 12 mm VITON
11	14CL06	x	Copriventola	Fan cover	Capot de ventilateur	Tapa del ventilador
12	14VN06	x	Ventola	Fan	Ventilateur	Ventilador
13	116001T	x	Vite	Screw	Vis	Tornillo
14	SC0600	x	Scudo	End shield	Flasque arrière	Tapa motor
15	116001T	x	Vite	Screw	Vis	Tornillo
16	SC070LN	x	Lanterna di raccordo	Motor bracket	Lanterne de raccordement	Soporte motor
17	115104	x	Deflettore	Deflector	Deflecteur	Deflector
18	RTP061C15B	x	Albero con rotore	Shaft with rotor	Arbre avec rotor	Eje con rotor
19	114000	x	Molla di compensazione	Compensation spring	Ressort de compensation	Muelle de compensación
20	113001	x	Cuscinetto a sfere	Ball bearing	Roulement à billes	Rodamiento
21	1160508	x	Vite	Screw	Vis	Tornillo
22	14COP08C	x	Coprimorsettiera	Terminal box	Couvercle de boîtier à bornes	Tapa bornes
23	114447	x	Morsettiera	Terminal board	Boîte à bornes	Placa bornes
24	111012F	x	Condensatore 12,5 µF	Capacitor 12,5 µF	Condensateur 12,5 µF	Condensador 12,5 µF
25	117960CV	x	Interruttore luminoso	Luminuos switch	Interrupteur lumineux	Interruptor lumiso
26	116032	x	Vite	Screw	Vis	Tornillo
27	14COP07I	x	Coprimorsettiera	Terminal box	Couvercle de boîtier à bornes	Tapa bornes
28	116031T	x	Vite	Screw	Vis	Tornillo
29	ASSPG9SVCK	x	Cavo di alimentazione H05 RN-F 1,5m con pressacavo	H05 RN-F 1,5m supply cable with cable gland	Câble d'alimentation H05 RN-F avec presse étoupe	Cable de alimentación H05 RN-F con prensacable
30	CA061CP0A1	x	Cassa motore con statore avvolto (V 230)	Motor casing with windings (V 230)	Carcasse moteur avec bobinage (V 230)	Caja motor con estator bobinado (V 230)

PROTEZIONE IP55 - IP55 PROTECTION - PROTECTION IP55 - PROTECCION IP55

14	SC06001	x	Scudo	End shield	Flasque arrière	Tapa motor
31	119012	x	Tappo	Plug	Bouchon	Tapón
32	11514501215	x	Anello di tenuta	Sealing ring	Joint a lèvres	Anillo de cierre
33	117055	x	Guarnizione	Gasket	Joint	Junta
34	117050	x	Guarnizione	Gasket	Joint	Junta
35	1151045	x	Anello di tenuta	Sealing ring	Joint a lèvres	Anillo de cierre

Con riserva di modifiche.
 Technical modifications reserved.
 Sous réserve de modification technique.
 Reservado el derecho a introducir modificaciones.

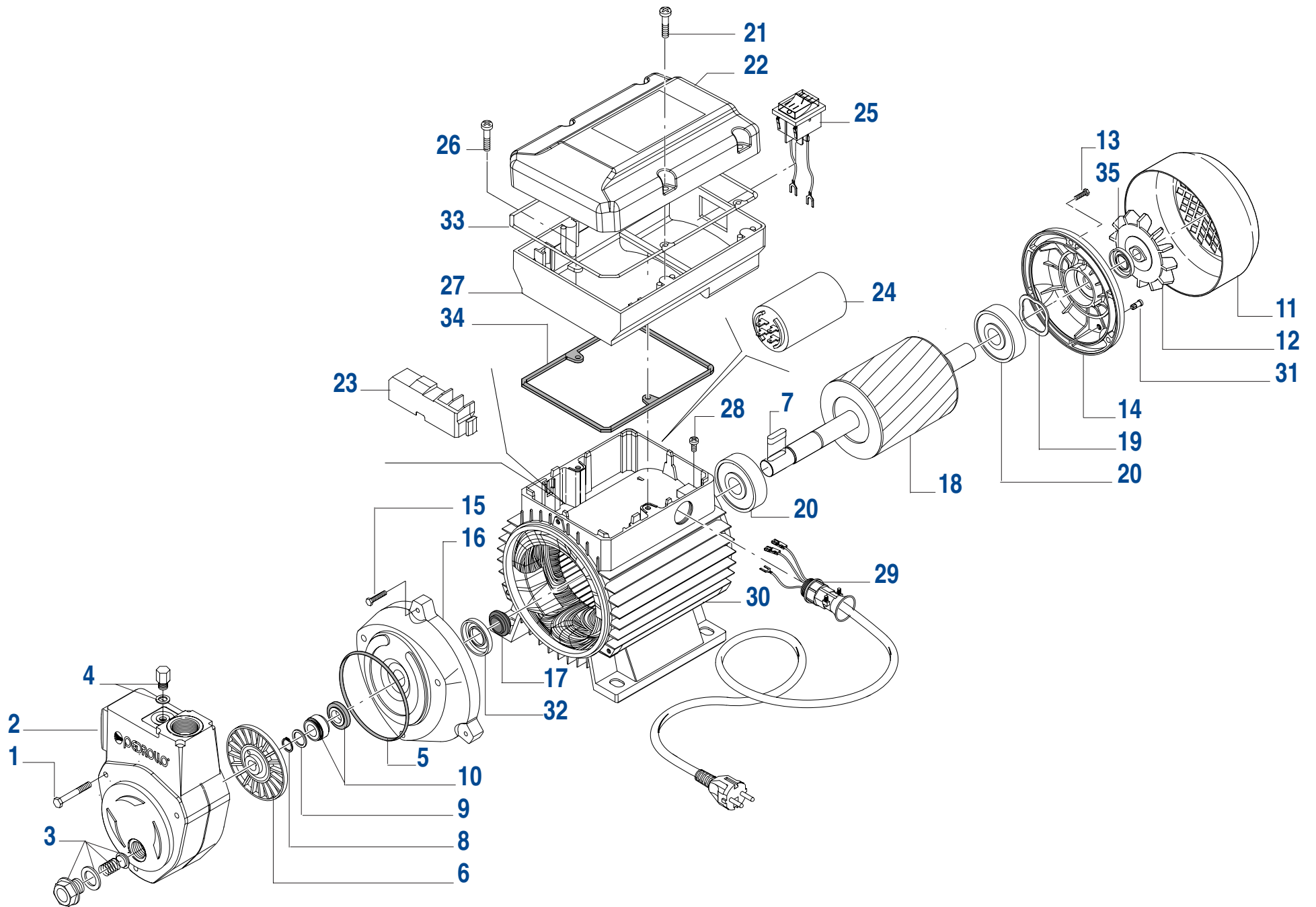

02.40.02

N°	Codice Code Reference Codigo	CKm 50-BP/INT	Descrizione	Description	Description	Descripción
1	1160451	x	Vite corpo pompa	Pump body screw	Vis du corps de pompe	Tornillo del cuerpo bomba
2	851CRCK50	x	Corpo pompa	Pump body	Corps de pompe	Cuerpo bomba
3	119009	x	Tappo con valvola	Plug with valve	Bouchon avec clapet	Tapón con válvula
4	119000C1	x	Tappo con rondella	Plug with washer	Bouchon avec rondelle	Tapón con arandela
5	11514202362	x	Guarnizione OR per corpo pompa	Pump body O-Ring	Joint torique du corps de pompe	Junta tórica del cuerpo bomba
6	860GRCK50	x	Girante	Impeller	Roue	Rodete
7	114800	x	Linguetta inox per girante	Stainless steel impeller key	Clavette de la roue en acier inox	Chaveta del rodete en acero inoxidable
8	114600	x	Anello di sicurezza Ø 12 mm	Circlip Ø 12 mm	Circlips Ø 12 mm	Anillo de seguridad Ø 12 mm
9	114700P	x	Rondella	Washer	Rondelle	Arandela
10	11516101203	x	Tenuta meccanica Ø 12 mm VITON	Mechanical seal Ø 12 mm VITON	Garniture mécanique Ø 12 mm VITON	Sello mecánico Ø 12 mm VITON
11	14CL06	x	Copriventola	Fan cover	Capot de ventilateur	Tapa del ventilador
12	14VN06	x	Ventola	Fan	Ventilateur	Ventilador
13	116001T	x	Vite	Screw	Vis	Tornillo
14	SC0600	x	Scudo	End shield	Flasque arrière	Tapa motor
15	116001T	x	Vite	Screw	Vis	Tornillo
16	SC070LN	x	Lanterna di raccordo	Motor bracket	Lanterne de raccordement	Soporte motor
17	115104	x	Deflettore	Deflector	Deflecteur	Deflector
18	RTP061C15B	x	Albero con rotore	Shaft with rotor	Arbre avec rotor	Eje con rotor
19	114000	x	Molla di compensazione	Compensation spring	Ressort de compensation	Muelle de compensación
20	113001	x	Cuscinetto a sfere	Ball bearing	Roulement à billes	Rodamiento
21	1160508	x	Vite	Screw	Vis	Tornillo
22	14COP08C	x	Coprimorsettiera	Terminal box	Couvercle de boîtier à bornes	Tapa bornes
23	114447	x	Morsettiera	Terminal board	Boîte à bornes	Placa bornes
24	111012F	x	Condensatore 12,5 µF	Capacitor 12,5 µF	Condensateur 12,5 µF	Condensador 12,5 µF
25	117960CV	x	Interruttore luminoso	Luminuos switch	Interrupteur lumineux	Interruptor lumiso
26	116032	x	Vite	Screw	Vis	Tornillo
27	14COP07I	x	Coprimorsettiera	Terminal box	Couvercle de boîtier à bornes	Tapa bornes
28	116031T	x	Vite	Screw	Vis	Tornillo
29	ASSPG9SVCK	x	Cavo di alimentazione H05 RN-F 1,5m con pressacavo	H05 RN-F 1,5m supply cable with cable gland	Câble d'alimentation H05 RN-F avec presse étoupe	Cable de alimentación H05 RN-F con prensacable
30	CA061CP0A1	x	Cassa motore con statore avvolto (V 230)	Motor casing with windings (V 230)	Carcasse moteur avec bobinage (V 230)	Caja motor con estator bobinado (V 230)

PROTEZIONE IP55 - IP55 PROTECTION - PROTECTION IP55 - PROTECCION IP55

14	SC06001	x	Scudo	End shield	Flasque arrière	Tapa motor
31	119012	x	Tappo	Plug	Bouchon	Tapón
32	11514501215	x	Anello di tenuta	Sealing ring	Joint a lèvres	Anillo de cierre
33	117055	x	Guarnizione	Gasket	Joint	Junta
34	117050	x	Guarnizione	Gasket	Joint	Junta
35	1151045	x	Anello di tenuta	Sealing ring	Joint a lèvres	Anillo de cierre

Con riserva di modifiche.
 Technical modifications reserved.
 Sous réserve de modification technique.
 Reservado el derecho a introducir modificaciones.

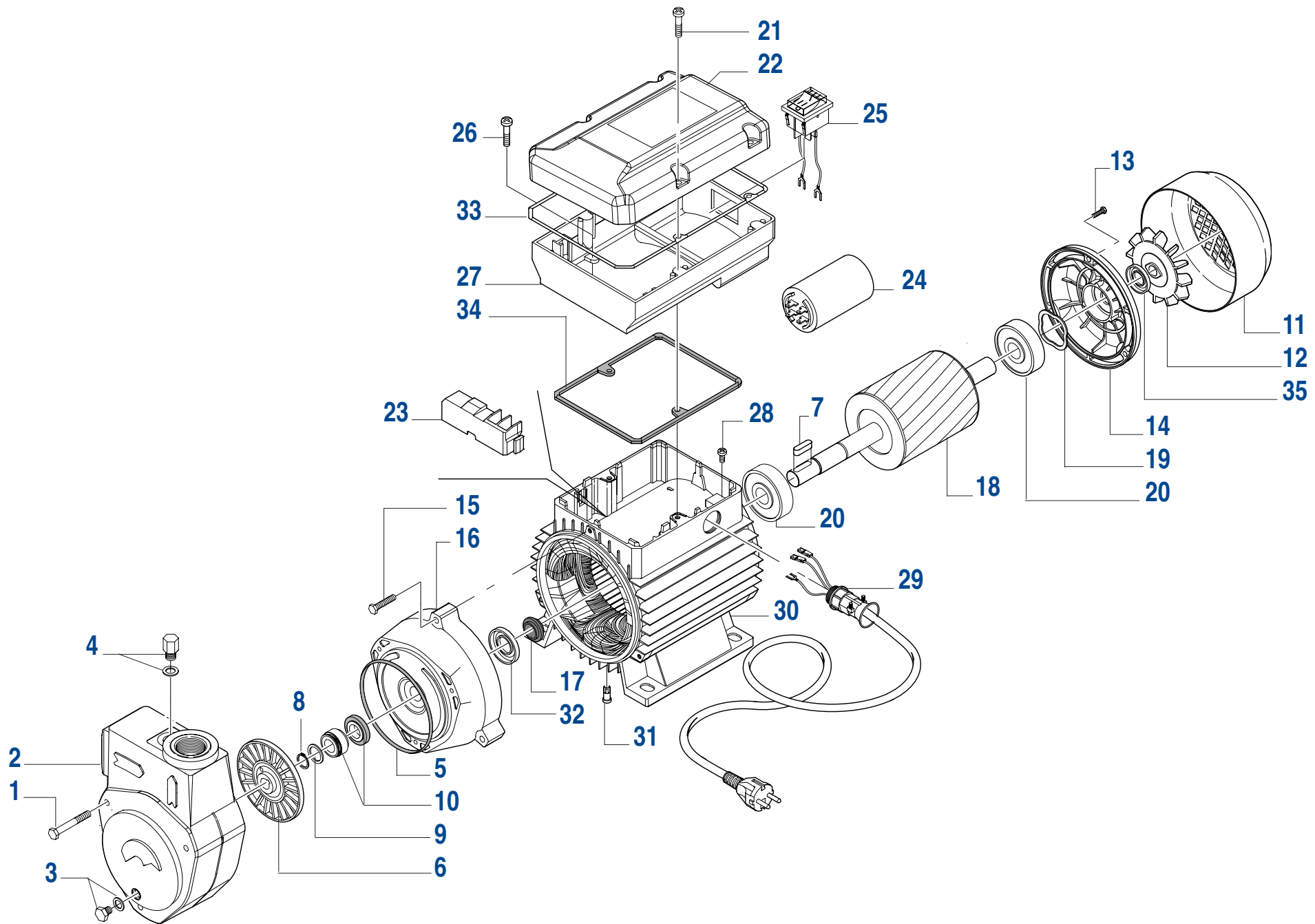

02.40.02

N°	Codice Code Reference Codigo	CKm 80/INT	CKm 90/INT	Descrizione	Description	Description	Descripción
1	1160081	x	x	Vite corpo pompa	Pump body screw	Vis du corps de pompe	Tornillo del cuerpo bomba
2	851CRCK80	x	x	Corpo pompa	Pump body	Corps de pompe	Cuerpo bomba
3	119003C	x	x	Tappo con rondella	Plug with washer	Bouchon avec rondelle	Tapón con arandela
4	119000C1	x	x	Tappo con rondella	Plug with washer	Bouchon avec rondelle	Tapón con arandela
5	11514202364	x	x	Guarnizione OR per corpo pompa	Pump body O-Ring	Joint torique du corps de pompe	Junta tórica del cuerpo bomba
6	860GRCK80	x	x	Girante	Impeller	Roue	Rodete
7	114800	x	x	Linguetta inox per girante	Stainless steel impeller key	Clavette de la roue en acier inox	Chaveta del rodete en acero inoxidable
8	114600	x	x	Anello di sicurezza Ø 12 mm	Circlip Ø 12 mm	Circlips Ø 12 mm	Anillo de seguridad Ø 12 mm
9	114700P	x	x	Rondella	Washer	Rondelle	Arandela
10	11516101203	x	x	Tenuta meccanica Ø 12 mm VITON	Mechanical seal Ø 12 mm VITON	Garniture mécanique Ø 12 mm VITON	Sello mecánico Ø 12 mm VITON
11	14CL07	x	x	Copriventola	Fan hood	Capot de ventilateur	Tapa del ventilador
12	14VN07	x	x	Ventola	Fan	Ventilateur	Ventilador
13	116001	x	x	Vite	Screw	Vis	Tornillo
14	SC0700	x	x	Scudo	End shield	Flasque arrière	Tapa motor
15	116020	x	x	Vite	Screw	Vis	Tornillo
16	SC075LN	x	x	Lanterna di raccordo	Motor bracket	Lanterne de raccordement	Soporte motor
17	115105	x	x	Deflettore	Deflector	Deflecteur	Deflector
18	RFP071C12	x	x	Albero con rotore	Shaft with rotor	Arbre avec rotor	Eje con rotor
19	114001	x	x	Molla di compensazione	Compensation spring	Ressort de compensation	Muelle de compensación
20	113002	x	x	Cuscinetto a sfere	Ball bearing	Roulement à billes	Rodamiento
21	1160508	x	x	Vite	Screw	Vis	Tornillo
22	14COP08C	x	x	Coprimorsettiera	Terminal box	Couvercle de boîtier à bornes	Tapa bornes
23	114447	x	x	Morsettiera	Terminal board	Boîte à bornes	Placa bornes
24	111016F	x	x	Condensatore 16 µF	Capacitor 16 µF	Condensateur 16 µF	Condensador 16 µF
24	111020F	x	x	Condensatore 20 µF	Capacitor 20 µF	Condensateur 20 µF	Condensador 20 µF
25	117960CV	x	x	Interruttore luminoso	Luminous switch	Interrupteur lumineux	Interruptor lumiso
26	116032	x	x	Vite	Screw	Vis	Tornillo
27	14COP07I	x	x	Coprimorsettiera	Terminal box	Couvercle de boîtier à bornes	Tapa bornes
28	116031	x	x	Vite	Screw	Vis	Tornillo
29	ASSPG11SVCK	x	x	Cavo di alimentazione H05 RN-F 1,5m con pressacavo	H05 RN-F 1,5m supply cable with cable gland	Câble d'alimentation H05 RN-F avec presse étoupe	Cable de alimentación H05 RN-F con prensacable
30	CA071CP0A1	x	x	Cassa motore con statore avvolto (V 230)	Motor casing with windings (V 230)	Carcasse moteur avec bobinage (V 230)	Caja motor con estator bobinado (V 230)

PROTEZIONE IP55 - IP55 PROTECTION - PROTECTION IP55 - PROTECCION IP55

14	SC07001	x	x	Scudo	End shield	Flasque arrière	Tapa motor
31	119012	x	x	Tappo	Plug	Bouchon	Tapón
32	11514501223	x	x	Anello di tenuta	Sealing ring	Joint a lèvres	Anillo de cierre
33	117055	x	x	Guarnizione	Gasket	Joint	Junta
34	117050	x	x	Guarnizione	Gasket	Joint	Junta
35	1151046	x	x	Anello di tenuta	Sealing ring	Joint a lèvres	Anillo de cierre

Con riserva di modifiche.
 Technical modifications reserved.
 Sous réserve de modification technique.
 Reservado el derecho a introducir modificaciones.

02.40.02

CKm 80/INT (A) - CKm 90/INT (A)

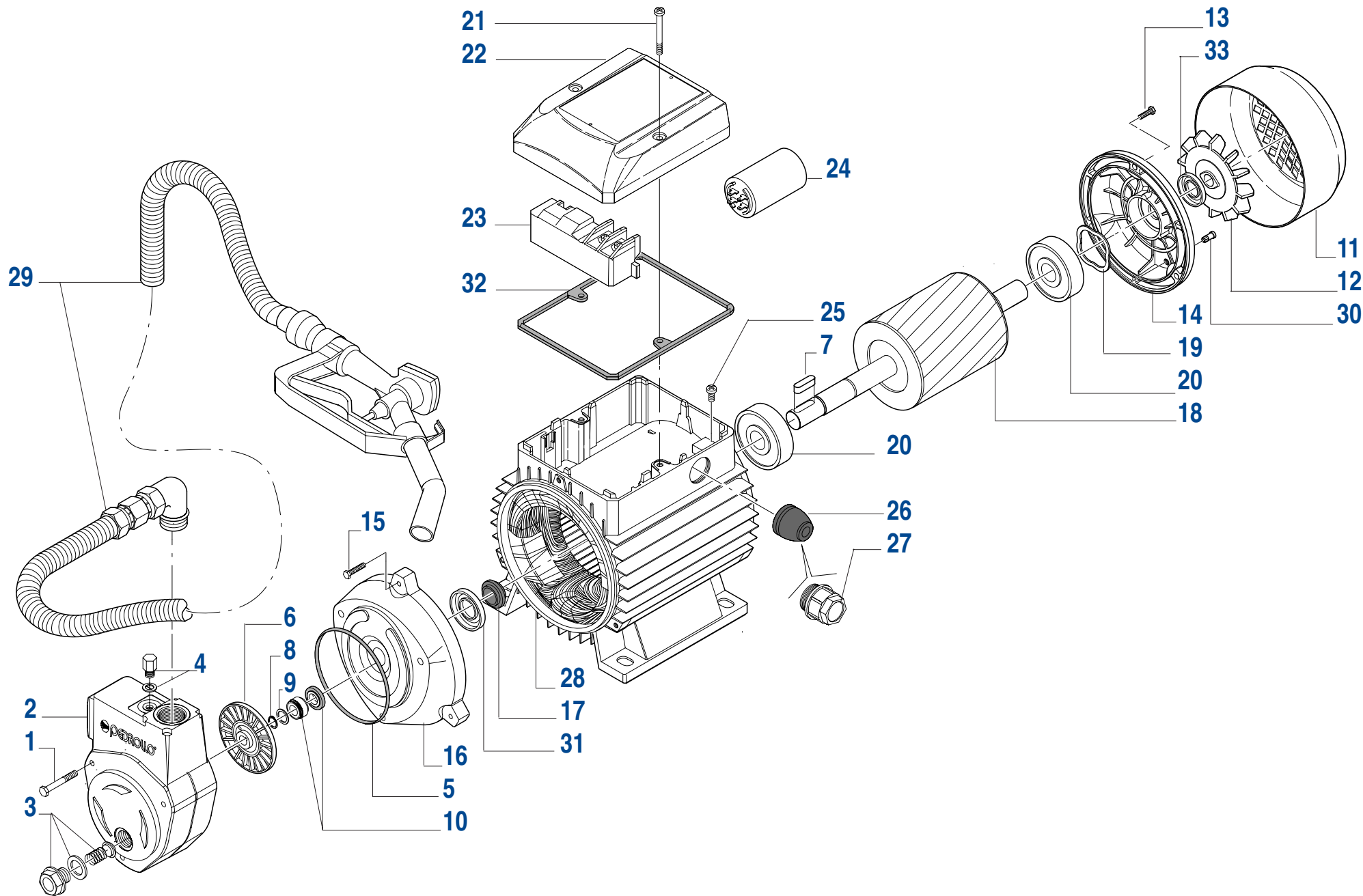

02.40.02

N°	Codice Code Reference Codigo	CKm 50-BP/NZ	Descrizione	Description	Description	Descripción
1	1160451	x	Vite corpo pompa	Pump body screw	Vis du corps de pompe	Tornillo del cuerpo bomba
2	851CRCK50	x	Corpo pompa	Pump body	Corps de pompe	Cuerpo bomba
3	119009	x	Tappo con valvola	Plug with valve	Bouchon avec clapet	Tapón con válvula
4	119000C1	x	Tappo con rondella	Plug with washer	Bouchon avec rondelle	Tapón con arandela
5	11514202362	x	Guarnizione OR per corpo pompa	Pump body O-Ring	Joint torique du corps de pompe	Junta tórica del cuerpo bomba
6	860GRCK50	x	Girante	Impeller	Roue	Rodete
7	114800	x	Linguetta inox per girante	Stainless steel impeller key	Clavette de la roue en acier inox	Chaveta del rodete en acero inoxidable
8	114600	x	Anello di sicurezza Ø 12 mm	Circlip Ø 12 mm	Circlips Ø 12 mm	Anillo de seguridad Ø 12 mm
9	114700P	x	Rondella	Washer	Rondelle	Arandela
10	11516101203	x	Tenuta meccanica Ø 12 mm VITON	Mechanical seal Ø 12 mm VITON	Garniture mécanique Ø 12 mm VITON	Sello mecánico Ø 12 mm VITON
11	14CL06	x	Copriventola	Fan cover	Capot de ventilateur	Tapa del ventilador
12	14VN06	x	Ventola	Fan	Ventilateur	Ventilador
13	116001T	x	Vite	Screw	Vis	Tornillo
14	SC0600	x	Scudo	End shield	Flasque arrière	Tapa motor
15	116001T	x	Vite	Screw	Vis	Tornillo
16	SC070LN	x	Lanterna di raccordo	Motor bracket	Lanterne de raccordement	Soporte motor
17	115104	x	Deflettore	Deflector	Deflecteur	Deflector
18	RTP061C15B	x	Albero con rotore	Shaft with rotor	Arbre avec rotor	Eje con rotor
19	114000	x	Molla di compensazione	Compensation spring	Ressort de compensation	Muelle de compensación
20	113001	x	Cuscinetto a sfere	Ball bearing	Roulement à billes	Rodamiento
21	116038	x	Vite	Screw	Vis	Tornillo
22	14COK06IPA	x	Coprimorsettiera	Terminal box	Couvercle de boîtier à bornes	Tapa bornes
23	114421	x	Morsettiera	Terminal board	Boîte à bornes	Placa bornes
24	111012F	x	Condensatore 12,5 µF	Capacitor 12,5 µF	Condensateur 12,5 µF	Condensador 12,5 µF
25	116031T	x	Vite	Screw	Vis	Tornillo
26	117060	x	Passacavo	Cable grommet	Passe câble	Pasacable
27	117109	x	Pressacavo	Cable gland	Presse étoupe	Prensacable
28	CA061CP0A1	x	Cassa motore con statore avvolto (V 230)	Motor casing with windings (V 230)	Carcasse moteur avec bobinage (V 230)	Caja motor con estator bobinado (V 230)
29	50430B	x	Erogatore a pistola con tubo spiralato	Nozzle with spiral pipe	Kit de refoulement tuyau spiralé et pistolet	Pistola erogadora con tubo corrugado

PROTEZIONE IP55 - IP55 PROTECTION - PROTECTION IP55 - PROTECCION IP55

14	SC06001	x	Scudo	End shield	Flasque arrière	Tapa motor
21	116035	x	Vite	Screw	Vis	Tornillo
30	119012	x	Tappo	Plug	Bouchon	Tapón
31	11514501215	x	Anello di tenuta	Sealing ring	Joint a lèvres	Anillo de cierre
32	1170501	x	Guarnizione	Gasket	Joint	Junta
33	1151045	x	Anello di tenuta	Sealing ring	Joint a lèvres	Anillo de cierre

Con riserva di modifiche.
 Technical modifications reserved.
 Sous réserve de modification technique.
 Reservado el derecho a introducir modificaciones.